

HPERC-KBL-MC

Extreme Rugged Cold Plate Mount System with 7th Gen Intel® Xeon® Processor and MIL-DTL-38999 Connectors

Features

- VITA 75 Cold Plate mounting
- Intel® Xeon® Processor E3-1505M v6, quad-core
- 16GB DDR4-2400 with ECC soldered down
- Quad Gigabit Ethernet and 6x USB ports
- Available GPGPU on PCI Express x16 Gen3
- 3 independent displays (DVI/VGA)
- Wide temperature range: storage -40°C to +85°C, operating -40°C to +75°C
- OS support: Windows 10, RHEL 7.3

New



Specifications

Processor & System

CPU

Intel® Xeon® E3-1505M v6 3.0GHz, Quad core

Chipset

Intel® CM238 Chipset

GPGPU

MXM NVIDIA Quadro series with 4GB GDDR5 (optional)

Memory

16GB DDR4-2400 ECC soldered down

BIOS

AMI EFI

Expansion Busses

MXM (PCIe x16 GEN3)

PCI/104 Express Type 2 (PCIe Gen2)

PCI Express Mini Card (PCIe Gen2)

Standard I/O

Video

2x DVI and 1x VGA (3 simultaneous display outputs)

Audio

1x amplified stereo output

1x stereo input

LAN Chipset

4x Intel® I210 Ethernet controller

LAN Speed

10/100/1000 Mbps

USB

6x USB 2.0

Serial Port

7x RS-232/422

GPIO

8x digital IO

Internal Storage

Removable SATA

2x 2.5" SLC/MLC SSD on SATA 6 Gb/s

RAID 0/1

Support up to 12Gb/s

Removable SD

1x SDHC - SLC (up to 64 GB)

Security

TPM

Infineon SLB 9665XT2.0

Secure Erase

Hardware input triggered

Software triggered

Power

Input: 18-36VDC

Performance: S-States S3, S4

Thermal

Internal Transfer: Passive conduction to body

Cold plate conduction

VITA 75.22 mount

Storage Temperature

-40°C to +85°C

Operating Temperature

Extreme Rugged: -40°C to +75°C (ambient)

(Note: Max. operating temperature is dependent on an external thermal solution design that keeps the temperature at any point on the cold plate surface below +85°C.)

Specifications

- **Certifications & Standards**

Immersion

IEC60529 - IP-67

Salt Spray

RTCA/DO-160G, Section 14, Category S

Altitude

0 to 50000 ft.

Relative Humidity

95% at +60°C non-condensing

Shock

MIL-STD-810G - 516.6 Procedures I and V

Vibration

MIL-STD-810G - 514.6 Procedure I
 Categories 4, 9, 11, 21

EMI/EMC

MIL-STD-461F

Power

MIL-STD-704F & MIL-STD-1275E

Operating Temp.

MIL-STD-810G - 501.5 Procedure II
 MIL-STD-810G - 502.5, Procedure 1 and 2

- **Mechanical**

Form Factor

VITA-75 Finned Passive Convection

Dimension (mm)

223.7(L) x 177.8(W) x 98.7(H)

Weight

4.68 kg

IO Connectors

MIL-DTL-38999 (uniquely-keyed)

- **Operating System**

OS

Windows® 10 (64-bit)

RHEL 7.3

(Please contact ADLINK for other OS support)

Functional Diagram

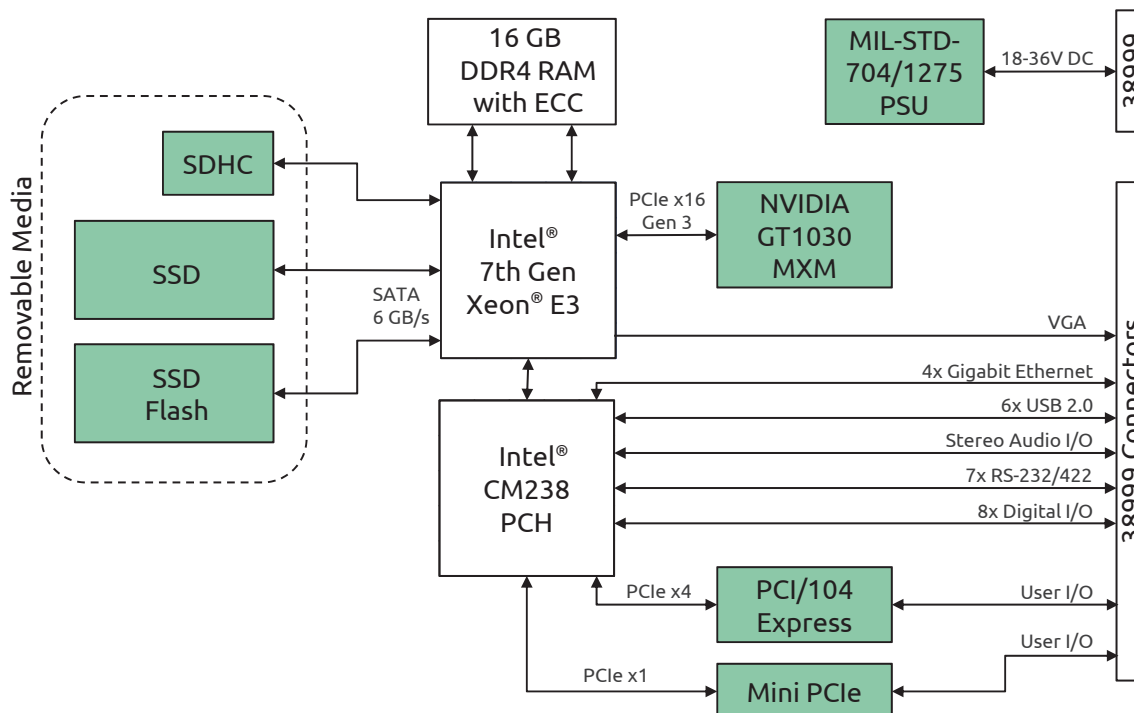

Mechanical Drawing

(Units: mm)

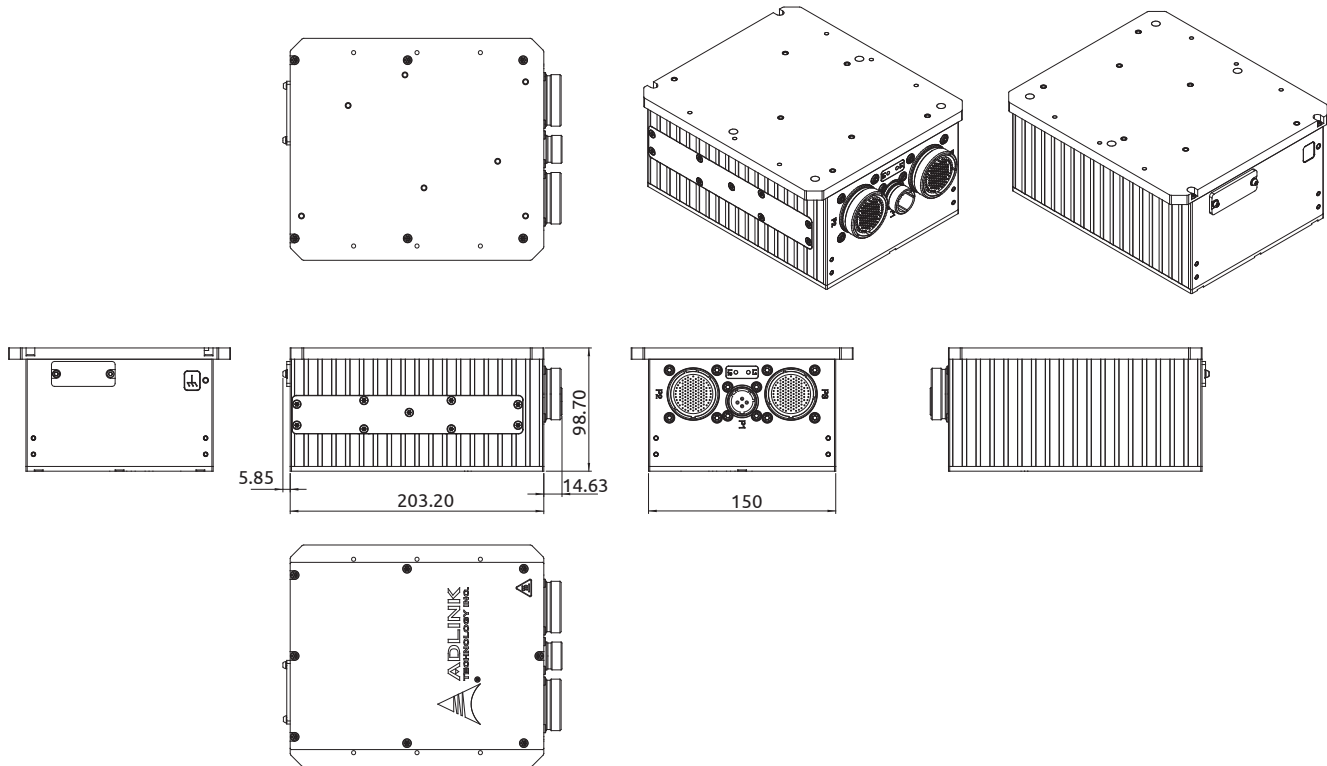

Ordering Information

- **HPERC-KBLMC-100XN**
Cold plate, Intel® Xeon® E3-1505M v6, 16GB RAM

HPERC Accessories

- **HPERC-X-03**
HPERC breakout cable kit including Amphenol MIL-STD Nkey & Akey (I/O cables), and AC Adapter
- **GPGPU MXM module**
MXM NVIDIA Quadro P1000 GPU card, with 4GB GDDR5 memory
(must be pre-assembled at ADLINK factory)