

VPX3010 Series

Rugged 3U VPX Intel® Xeon® Processor D-1500 Processor Blade

Features

- Intel® Xeon® Processor D-1500 SoC up to 12 cores (formerly “Broadwell-DE”)
- DDR4-2133 soldered ECC SDRAM up to 16GB
- Dual 10G-KR, up to three 1G Ethernet ports
- Up to PCIe x16 Gen3 interface supporting non-transparent bridge
- One XMC expansion slot, PCIe x8 Gen3 with Rear I/O to P2

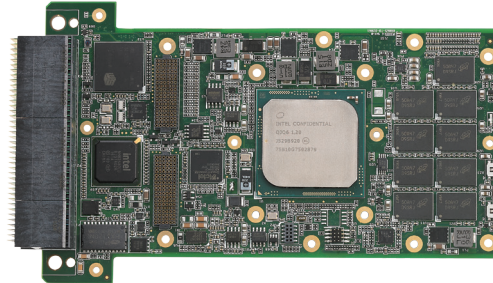

Specifications

• Processor & System

CPU

Intel® Xeon® D-1559 12-core, 45W TDP

Intel® Xeon® D-1539 8-core, 35W TDP

Intel® Pentium® D1519 4-core, 25W TDP

RAM

Dual channel DDR4-2133 ECC soldered SDRAM, up to 16GB

BIOS

AMI EFI on 64Mbit SPI flash

VITA Specifications

VITA 46.0 VPX Base Standard

VITA 46.4 PCI Express on VPX Fabric Connector

VITA 46.6 Gigabit Ethernet Control Plane on VPX

VITA 46.9 PMC/XMC/Ethernet Signal Mapping to 3U/6U VPX

VITA 46.10 Rear Transition Module on VPX

VITA 46.11 System Management on VPX

VITA 48.0 Ruggedized Enhanced Design Implementation Mechanical Base Specification

VITA 65 OpenVPX Architecture Framework for VPX

Module Profile

MOD3-PAY-2F2T-16.2.5-3

Slot Profile

SLT3-PAY-2F2T-14.2.5

• Connectivity

XMC

PCIe x8 Gen3 with Rear IO to P2 X8d+X12d

Ethernet

Dual 10G-KR to P2

Two 1000BASE-T to P1 (or one 1000BASE-T and two 1000BASE-BX by BOM option)

Graphics

SMI750 on PCIe x1

One VGA to P2

USB

One USB 3.0 to P1 and one to P2

One USB 2.0 to P1

Serial Port

One RS-232 to P1

One RS-232/422 to P1

PCI Express

PCIe x8 Gen3, configurable to 1 x8 or 2 x4 to P1, supports DMA and non-transparent bridge for peer-to-peer communication

PCIe x8 Gen3 to P2 (combined with PCIe x8 Gen3 to P1 for PCIe x16 Gen3, no XMC BOM option)

PCIe x1 Gen3 to P1 (no XMC BOM option)

• Storage

SBC

Soldered SLC NAND flash up to 64GB SATA 6Gb/s

RTM

One SATA 6Gb/s to P1

One SATA 6Gb/s to P2 (no XMC BOM option)

Specifications

- **Security Mechanism**

TPM

Atmel TPM version 1,2

IPMC

Smart Fusion A2F200 with VPX code base

BIOS

Dual BIOS mechanism

- **Operating System**

OS

Red Hat Enterprise Linux 6.5

Wind River VxWorks 7.0

Microsoft Windows 7 32/64-bit

Microsoft Windows 7 Embedded (Please contact ADLINK for other OS support)

- **Miscellaneous**

LEDs

Blade status LEDs on front and rear

Watchdog Timer

System reset or NMI with programmable interval

GPIO

Eight 5V tolerance GPIO to P1 and P2

Reset Button

Reset button on front panel

- **Miscellaneous**

Form Factor

3U VPX 1.0 in. pitch

Operating Temp.

-40°C to +85°C (at wedge locks)

Storage Temp.

-50°C to +100°C

Relative Humidity

95% non-condensing

Shock

5Hz-2KHz, 12Grms, random, each axis, operating

Vibration

Sawtooth 40G, 11ms, each axis, operating

Altitude

60,000 feet, operating

Power Consumption

TBD

Weight

TBD

Thermal Dissipation

Convection and conduction

- **Safety & EMI**

Certifications

CE, FCC Class A

VPX3010 Block Diagram

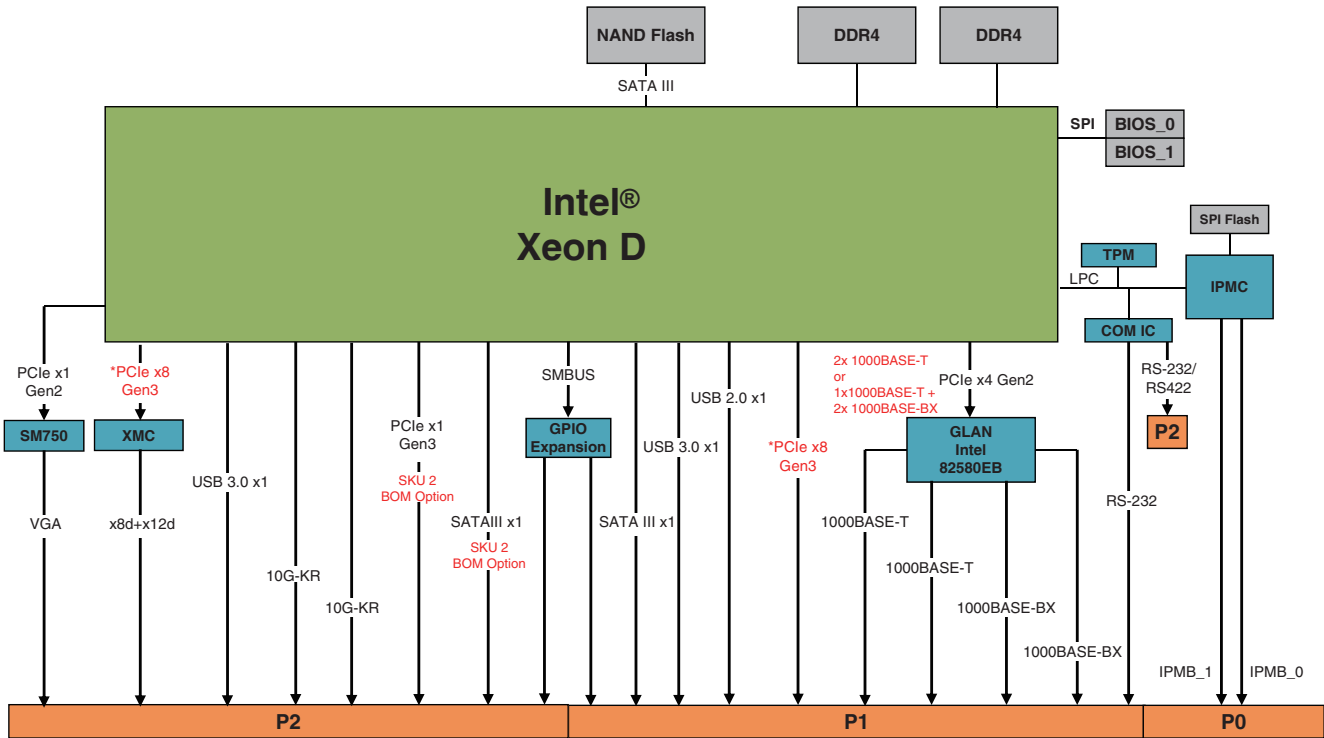

* Combined with PCIe x8 Gen3 to P1 and PCIe x8 to PCIe x16 Gen3, No XMC BOM option
 * The data transfer rate will be limited by device specification

Companion Production Information 3U VPX Test Frame

VPX 3U Graphics Card



VPX3G10

- NVIDIA GeForce GT 745M GPU (Kepler refresh)
- 384 CUDA cores for maximum processing power
- Dual channel GDDR5 soldered memory, 2GB
- 16-lanes PCIe Gen3 (x16/x8/x4/x1) to P1
- Four single link DVI and One VGA to P2
- Support OpenVPX Profile:
- MOD3-PER-2F-16.3.1-3 and MOD3-PER-1F-16.3.2-2

Product Type	9-slot Test Frame
Form Factor	VPX 3U
Dimensions	142.6mm (H) x 209.9mm (W) x 276.28mm (D)
Blade Support	Conduction cooled VPX 3U blades
Backplane Support	3-slot
RTM Support	Yes
Cooling	Passive fins
Power	User define

XMC Graphics Module



XMC-G745-R1

- NVIDIA GeForce GT 745M GPU (Kepler refresh)
- 384 CUDA cores for maximum processing power
- Dual channel GDDR5 soldered memory, 2GB
- 16-lanes PCIe Gen3 (x16/x8/x4/x1) on P15
- Four single link DVI and One VGA ON p16



3U VPX Test Frame

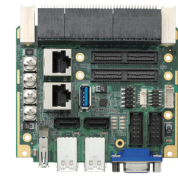

VPX-R3010

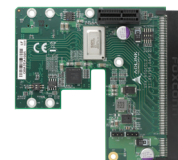

VPX-R3010L2

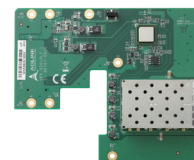

VPX-R3010L2-1

Ordering Information

Processor Blades

- **VPX3010/1559/M16/S32/XMC-R1**
3U VPX processor board with Intel® Xeon® D-1559, DDR4 16GB, SLC 32GB, dual 10G-KR, dual GbE Base-T, VGA, 2x USB 3.0, XMC slot with coating & ETT -40°C to +75°C, conduction cooled
- **VPX3010/1559/M16/S32/P16-R1**
3U VPX processor board with Intel® Xeon® D-1559, DDR4 16GB, SLC 32GB, PCIe x16, dual 10G-KR, 1GbE Base-T and GbE Base-BX, VGA, 2x USB 3.0, with coating & ETT -40°C to +75°C, conduction cooled
- **VPX3010/1539/M16/S32/XMC-R1**
3U VPX Processor Board Intel® Xeon® D-1539, DDR4 16GB, SLC 32GB, dual 10G-KR, dual GbE Base-T, VGA, 2x USB 3.0, XMC slot with coating & ETT -40°C to +75°C, conduction cooled
- **VPX3010/1539/M16/S32/P16-R1**
3U VPX Processor Board Intel® Xeon® D-1539, DDR4 16GB, SLC 32GB, PCIe x16, dual 10G-KR, 1GbE Base-T and GbE Base-BX, VGA, 2x USB 3.0, with coating & ETT -40°C to +75°C, conduction cooled
- **VPX3010/1559/M16/S64/XMC-R1**
3U VPX processor board with Intel® Xeon® D-1559, DDR4 16GB, SLC 64GB, dual 10G-KR, dual GbE Base-T, VGA, 2x USB 3.0, XMC slot with coating & ETT -40°C to +75°C, conduction cooled
- **VPX3010/1559/M16/S64/P16-R1**
3U VPX Processor board with Intel® Xeon® D-1559, DDR4 16GB, SLC 64GB, PCIe x16, dual 10G-KR, GbE Base-T and GbE Base-BX, VGA, 2x USB 3.0 with coating & ETT -40°C to +75°C, conduction cooled

Rear Transition Modules

- **VPX-R3010**
RTM for VPX3010 with GbE, SATA, USB 3.0/2.0, RS-232, GPIO
- **VPX-R3010L2**
RTM for VPX-R3010 with PCIe x16 slot, PCIe x1 slot
- **VPX-R3010L2-1**
RTM for VPX-R3010 with 10G SFP+ connector

Accessories

- **VPX3G10-R**
3U VPX NVIDIA GT745M GPU blade, 384 CUDA GDDR5 2GB, conduction cooled
- **XMC-G745-R**
XMC NVIDIA GT745M GPGPU module, 384 CUDA GDDR5 2GB, conduction cooled
- **VPX-TF3090**
3U VPX conduction cooled test frame with tBP-VPX3000