

COMh-sdID

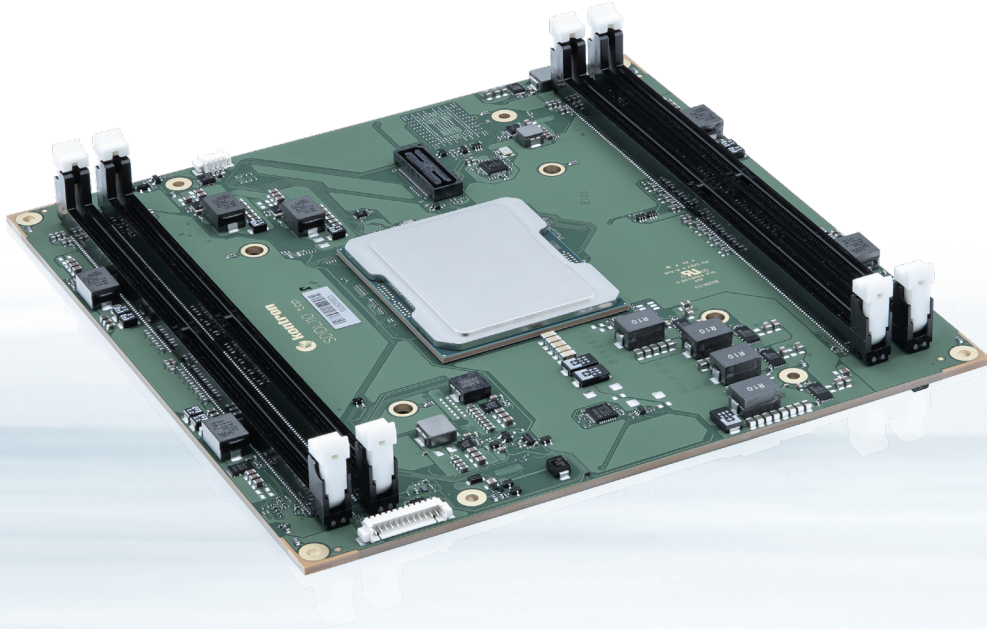

COM-HPC®/Server Size D with Intel® XEON® D-2700 SOC processors

- ▶ High-end server-grade platform
- ▶ 8x LAN Ports: versatile configurations up to 100G
- ▶ High-speed connectivity 32x PCIe 4.0 + 16x PCIe 3.0, SATA, USB 3.0
- ▶ Up to 1 TByte NVMe SSD onboard
- ▶ Industrial grade versions

▶ TECHNICAL INFORMATION

COMPLIANCE	COM-HPC®/Server, Size D
DIMENSIONS	160 x 160 mm
CPU (SoC)	Intel Xeon® D-2700 Processor Series For details see table "CPU variants" given below
CHIPSET	-
MAIN MEMORY	4x DDR4 DIMM sockets for up to 256 GByte RDIMM (512 GByte planned)
ETHERNET CONTROLLER	Intel® I226-LM/IT Intel® 2x Quad 25GbE LAN integrated in SoC
ETHERNET	1x 1/2.5 Gb Ethernet 8x Ethernet ports supporting versatile configurations: 100GbE/2x 50GbE/4x 25GbE/2x 25GbE + 4x 10GbE/8x 10GbE
STORAGE	2x SATA 6Gb/s
FLASH ONBOARD	Up to 1 TByte NVMe SSD (on request)
PCI EXPRESS®	32x PCIe Gen4 (2 x16, 4 x8, 8 x4) 16x PCIe Gen3 (2 x8, 4 x4, 8 x2)
USB	4x USB 3.0 / USB 2.0
SERIAL	2x serial interface (RX/TX only)
OTHER FEATURES	SPI, eSPI, SMB, Staged Watchdog, RTC
SPECIAL FEATURES	TPM 2.0
FEATURES ON REQUEST	NVMe SSD
POWER MANAGEMENT	ACPI 6.0
POWER SUPPLY	12V DC
BIOS	AMI UEFI
OPERATING SYSTEM	Linux, Windows 10 IoT Enterprise, Windows Server 2022
TEMPERATURE	Commercial temperature: 0 °C to +60 °C operating, -30 °C to +80 °C non-operating Industrial temperature: -40 °C to +80 °C operating, -40 °C to +80 °C non-operating
HUMIDITY	93 % relative Humidity at 40 °C, non-condensing (according to IEC 60068-2-78)
SUPPORTED MODULES	COMh-sdID xxxxx commercial grade COMh-sdID E2 xxxxx industrial grade

▶ CPU VARIANTS

PROCESSOR NUMBER	STD FOR COMh-sdID	TDP (W)	CORES	EXTEND TEMP	CACHE (MByte)	BASE FREQ (GHz)	ALL/MAX TURBO (GHz)	MEM-FREQ (MT/S)	LAN PORTS	QAT
D-2796TE	yes	118	20	yes	30	2.0	2.4/3.1	2933	8	no
D-2798NX	on request	126	20	no	30	2.1	2.6/3.1	2933	8	yes
D-2798NT	on request	125	20	no	30	2.1	2.6/3.1	3200	8	yes
D-2796NT	yes	120	20	no	30	2.0	2.5/3.1	2933	8	yes
D-2786NTE	on request	118	18	yes	27,5	2.1	2.5/3.1	2933	8	yes
D-2775TE	yes	100	16	yes	25	2.0	2.4/3.1	2933	8	no
D-2777NX	on request	116	16	no	25	2.2	2.7/3.3	2667	8	yes
D-2776NT	yes	117	16	no	25	2.1	2.6/3.2	2933	8	yes
D-2766NT	on request	97	14	no	20	2.0	2.5/3.1	2667	8	yes
D-2753NT	yes	87	12	no	20	2.0	2.5/3.1	2667	8	yes
D-2752TER	yes	77	12	yes	20	1.8	2.1/2.8	2667	8	no
D-2752NTE	on request	84	12	yes	20	1.9	2.3/3.0	2667	8	yes
D-2757NX	on request	107	12	no	20	2.5	3.0/3.5	2667	8	yes
D-2745NX	on request	96	10	no	17,5	2.4	2.9/3.5	2667	8	yes
D-2733NT	on request	80	8	no	15	2.1	2.6/3.2	2667	0	yes
D-2712T	on request	65	4	no	15	1.9	2.4/3.0	2667	0	no
D-2799	on request	129	20	no	30	2.4	2.6/3.4	3200	0	no
D-2779	on request	126	16	no	25	2.5	2.8/3.4	3200	0	no
D-2738	on request	88	8	no	15	2.5	3.0/3.5	2933	0	no

► BLOCK DIAGRAM

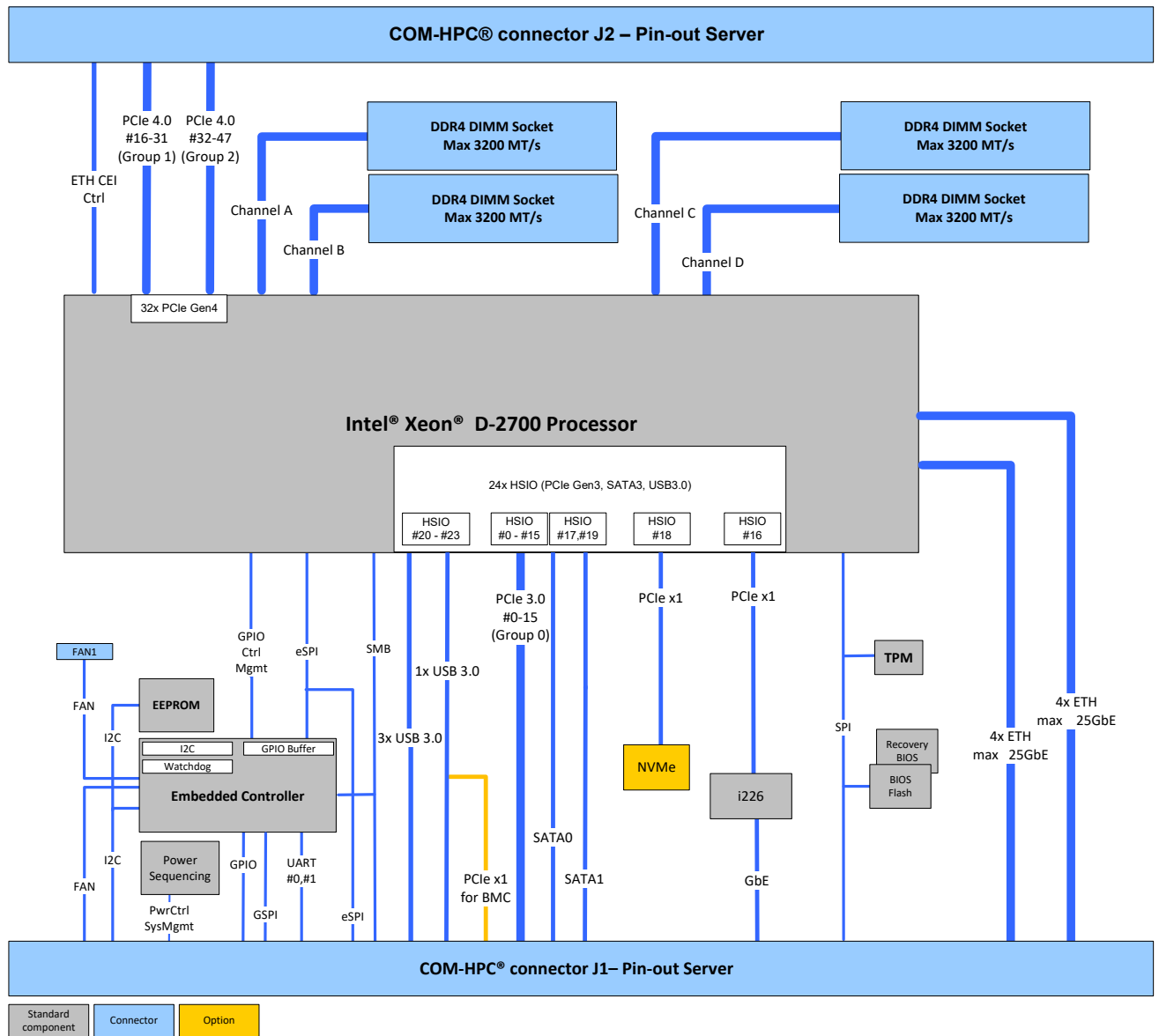

► VARIANTS

PART NO.	CPU	1/2.5 GbE	SOC-LAN	DIMM	NVMe	OP. TEMPERATURE
HSD01-0000-96-2	D-2796NT	I226-LM	8x LAN ports	4	no	0 °C to +60 °C
HSD01-0000-76-2	D-2776NT	I226-LM	8x LAN ports	4	no	0 °C to +60 °C
HSD01-0000-53-2	D-2753NT	I226-LM	8x LAN ports	4	no	0 °C to +60 °C
HSD02-0000-96-1	D-2796TE	I226-IT	8x LAN ports	4	no	-40 °C to +80 °C
HSD02-0000-75-1	D-2775TE	I226-IT	8x LAN ports	4	no	-40 °C to +80 °C
HSD02-0000-52-1	D-2752TER	I226-IT	8x LAN ports	4	no	-40 °C to +80 °C

Please contact your sales representative for other CPU versions or LAN configurations
 Please contact tech support for custom UEFI firmware
 On the COMh-sdID7 QAT is disabled by default - a custom UEFI firmware is required for QAT enabled

► CARRIER

ARTICLE	PART NO.	DESCRIPTION
COM-HPC/SERVER EVAL-CARRIER	HST01-0000-10-0	Eval-Carrier with 10-mm stack-up connector

► COOLING

ARTICLE	PART NO.	DESCRIPTION
COMh-sdID (E2) HSP THREADED	HSD01-0000-99-0	COMh-sdID (E2) heatspreader threaded
COMh-sdID (E2) HSP THROUGH HOLE	HSD01-0000-99-1	COMh-sdID (E2) heatspreader through hole
COMh SIZE D ACTIVE UNI COOLER (W/O HSP)	HSD99-0000-99-0	COM-HPC Size D Universal Active Cooler for Heatspreader Mounting (160 x 100 x 46 mm)
COMh SIZE D PASSIVE UNI COOLER (W/O HSP)	HSD99-0000-99-1	COM-HPC Size D Universal Passive Cooler for Heatspreader Mounting (160 x 100 x 46 mm)
COOLING COMh-sdID (E2): ADAPTER	HSD01-0000-99-A	Cooling Solution for COMh-sdID (E2), adapter for a standard LGA115x cooling solution. To be used with HSD01-0000-99-B & HSD01-0000-99-C
COOLING COMh-sdID (E2): BACKPLATE	HSD01-0000-99-B	Cooling Solution for COMh-sdID (E2), backplate To be used with HSD01-0000-99-A & HSD01-0000-99-C
COOLING COMh-sdID (E2): COOLER	HSD01-0000-99-C	Cooling Solution for COMh-sdID (E2), LGA115x cooler To be used with HSD01-0000-99-A & HSD01-0000-99-B

► MEMORY

PART NO.	DESCRIPTION	SIZE	ECC/NON-ECC	OP. TEMPERATURE
97100-0832-SDID	DDR4-3200 RDIMM	8 GByte	ECC	0 °C to +60 °C
97100-1632-SDID	DDR4-3200 RDIMM	16 GByte	ECC	0 °C to +60 °C
97100-3232-SDID	DDR4-3200 RDIMM	32 GByte	ECC	0 °C to +60 °C
97100-6432-SDID	DDR4-3200 RDIMM	64 GByte	ECC	0 °C to +60 °C
97101-0832-SDID	DDR4-3200 RDIMM	8 GByte	ECC	-40 °C to +85 °C
97101-1632-SDID	DDR4-3200 RDIMM	16 GByte	ECC	-40 °C to +85 °C
97101-3232-SDID	DDR4-3200 RDIMM	32 GByte	ECC	-40 °C to +85 °C
97101-6432-SDID	DDR4-3200 RDIMM	64 GByte	ECC	-40 °C to +85 °C

► GLOBAL HEADQUARTERS

Kontron Europe GmbH

Gutenbergstraße 2
85737 Ismaning, Germany
Tel.: +49 821 4086-0
Fax: +49 821 4086-111
info@kontron.com

www.kontron.com



Authorized Distributor

wdsystems.com

sales@wdsystems.com

800-548-2319

919-545-2500

220 Chatham Business Drive
Pittsboro, NC 27312