

EGPL-G102

M.2 to Single Isolated GbE LAN Module

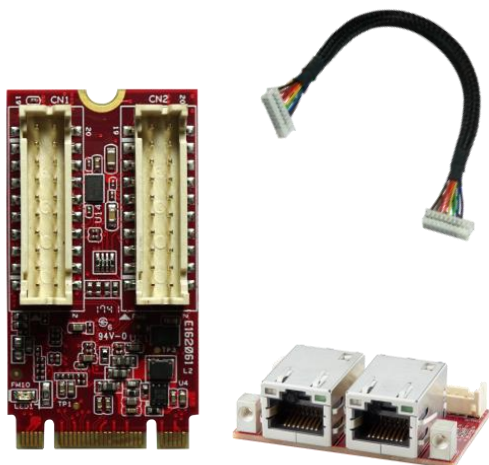

HIGHLIGHT FEATURES

- Intel i210 controller
- Complies with EN61000-4-5 2kV surge protection
- Complies with IEC 60950-1 : 2005 + A1 : 2009 + A2 : 2013 2kV HiPOT protection
- Complies with EN61000-4-2 (ESD) Air-15kV, Contact-8kV
- Flexible daughter board with cable to fit into different system
- Optional industrial temperature (-40°C to 85°C) support

SPECIFICATIONS

Model Name	EGPL-G102
Module Type	M.2 to Single Isolated GbE LAN Module
Form Factor	M.2 2242 B+M Key
Function	LAN
Input I/F	PCI Express 2.1 x1
Output I/F	GbE LAN
Output Port	1
Output Connector	RJ45
Max. Power Consumption	2.22W (3.3V, 675mA)
Dimension (W x L x H/mm)	Main Board : 22 x 42 x 9.01 Daughter Board : 28 x 50 x 19.37
Temperature	Operation : S/T 0°C ~ 70°C ; W/T -40°C ~ 85°C (Ta) Storage : -55°C ~ 95°C (Ta)
Vibration	5G@[7~2000Hz]
Shock	50G@0.5ms
OS Support	Windows : XP (32bit), 7 (32 / 64bit), 8 / 8.1 (32 / 64bit), 10 (32 / 64bit), and above version Linux : Kernel 2.4 series, 2.6.x, 3.x, and above version
Warranty	3 Years
Notes	<ul style="list-style-type: none">• Please download driver from Intel official website.

ORDER INFO.

P/N	Description
EGPL-G102-C1	M.2 2242 to Single Isolated GbE LAN Module, Terminal Mounting Hole / Standard Temperature
EGPL-G102-W1	M.2 2242 to Single Isolated GbE LAN Module, Terminal Mounting Hole / Wide Temperature

MECHANICAL DRAWING

Main Board

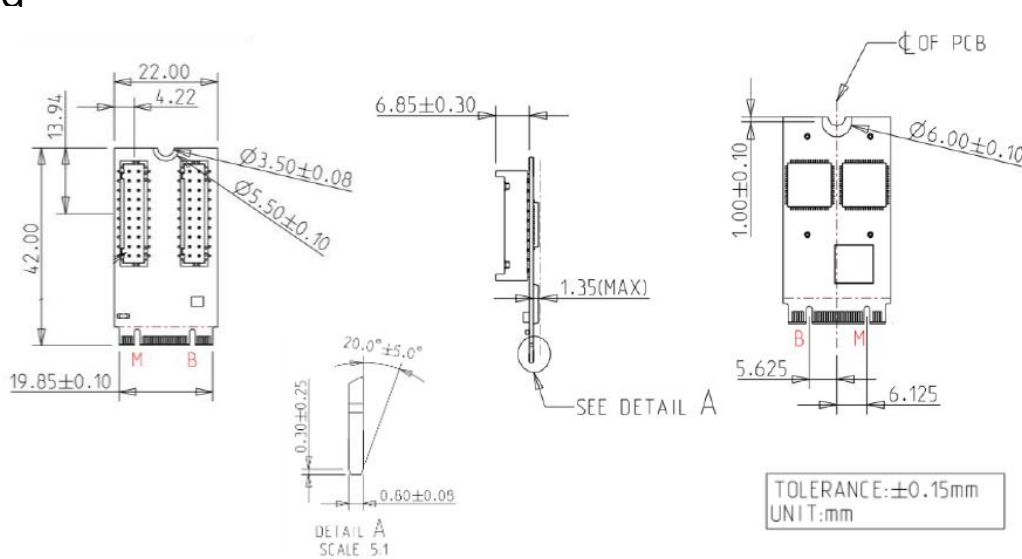

Daughter Board

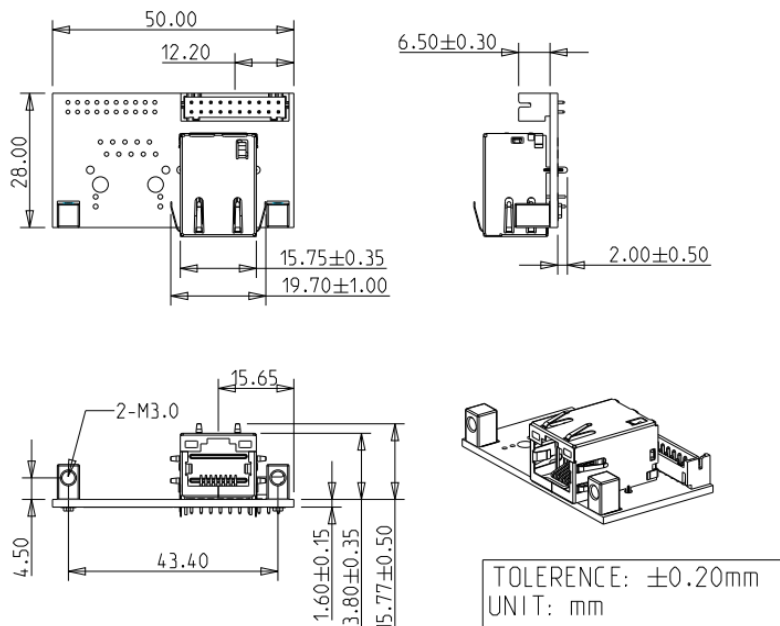

HQ (Taiwan) T +886-2-7703-3000 / E sales@innodisk.com

CN T +86-755-2167-3689 / E sales_cn@innodisk.com

US T +1-510-770-9421 / E usasales@innodisk.com

EU T +31-40-3045-400 / E eusales@innodisk.com

JP T +81-3-6667-0161 / E jp_sales@innodisk.com





Authorized Distributor

wdsystems.com

sales@wdsystems.com

800-548-2319

919-545-2500

220 Chatham Business Drive
Pittsboro, NC 27312