

COMe-cAL6 (E2)

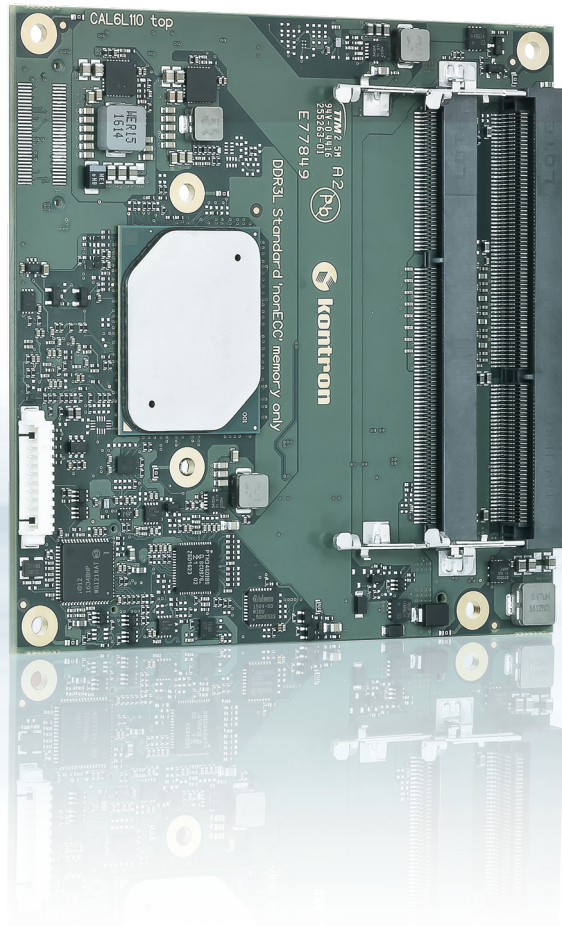

COM Express® Compact Type 6 with Intel Atom® E3900 Series, Pentium® and Celeron® Processors

- ▶ Low-power - performance/watt optimized form factor solution
- ▶ Up to 8 GByte DDR3L 1600/1866 Memory (2x SODIMM socket)
- ▶ 4x USB 3.0/2.0, 4x USB 2.0, 2x SATA, eMMC Flash
- ▶ Industrial grade temperature
- ▶ Support of Kontron's Embedded Security Solution - APPROTECT (optional)

POSSIBILITIES START HERE

▶ TECHNICAL INFORMATION

COMPLIANCE	COM Express® compact, Pin-out Type 6																
DIMENSIONS (H x W)	95 x 95 mm																
CPU	Intel Atom® E3900E Series, Pentium® and Celeron® Processor For details see table (CPU variants) given below																
CHIPSET	-																
MAIN MEMORY	2x SODIMM for DDR3L-1866 (non ECC) up to 8 GByte																
GRAPHICS CONTROLLER	Intel HD Gfx Gen9: 1x LVDS/eDP (3840 x 2160 @ 60 Hz) 2x DP (++) on DDI1/DDI2 up to 4K																
ETHERNET CONTROLLER	Intel® I210IT / I211AT																
ETHERNET	10/100/1000 MBit Ethernet																
STORAGE	2x SATA 6Gb/s, SDIO Interface (shared with GPIO)																
FLASH ONBOARD	32 GByte eMMC SLC on request: - up to 64 GByte eMMC SLC - up to 128 GByte eMMC MLC																
PCI EXPRESS®	<table border="1"> <thead> <tr> <th></th> <th>LAN</th> <th>PCIe switch</th> <th>PCIe config</th> </tr> </thead> <tbody> <tr> <td>default</td> <td>yes</td> <td>no</td> <td>3x PCIe x1</td> </tr> <tr> <td>on request</td> <td>yes</td> <td>yes</td> <td>5x PCIe x1 or 1x PCIe x2 + 3x PCIe x1</td> </tr> <tr> <td>on request</td> <td>no</td> <td>no</td> <td>2x PCIe x2 or 4x PCIe x1</td> </tr> </tbody> </table>		LAN	PCIe switch	PCIe config	default	yes	no	3x PCIe x1	on request	yes	yes	5x PCIe x1 or 1x PCIe x2 + 3x PCIe x1	on request	no	no	2x PCIe x2 or 4x PCIe x1
	LAN	PCIe switch	PCIe config														
default	yes	no	3x PCIe x1														
on request	yes	yes	5x PCIe x1 or 1x PCIe x2 + 3x PCIe x1														
on request	no	no	2x PCIe x2 or 4x PCIe x1														
DISPLAY	DDI 1/2: DP++, LVDS: Dual Channel up to 48-bit or eDP on request)																
USB	4x USB 3.0/2.0, 4x USB 2.0 (3x USB 2.0 w Security Chip)																
SERIAL	2x serial interface (RX/TX only)																
AUDIO	Intel® High Definition Audio																
COMMON FEATURES	SPI, LPC, SMB, Fast I ² C, Staged Watchdog, RTC																
BIOS	AMI Aptio V																
HUMIDITY	93 % relative Humidity at 40 °C, non-condensing (according to IEC 60068-2-78)																
FEATURES ON REQUEST	PCIe configurations w/ PCI hub and w/o LAN chip Security Chip (Support of Kontron APPROTECT) eMMC Flash configuration eDP instead of LVDS General Purpose SPI instead of Boot SPI USB client																
POWER MANAGEMENT	ACPI 5.0																
POWER SUPPLY	8.5 V – 20 V Wide Range, Single Supply Power																
SPECIAL FEATURES	POSCAP capacitors, Trusted Platform Module TPM 2.0, microSD card socket 4k Resolutions, GPIO/SDIO Switch, Industrial grade temperature																
OPERATING SYSTEM	Windows® 10, Enterprise, Windows 10 IoT, Linux, VxWorks 7.x																
TEMPERATURE	COMe-cAL6 - commercial temperature: 0 °C to +60 °C operating, -30 °C to +85 °C non-operating COMe-cAL6 E2 - industrial temperature: -40 °C to +85 °C operating, -40 °C to +85 °C non-operating																

CPU VARIANTS

BRAND	PROCESSOR NUMBER	TDP	CORES	THREADS	CACHE	BASE FREQ	MAX TURBO FREQ	GRAPHICS GEN 11	ECC	USE CONDITION
Celeron®	N3350E	6 W	2	2	2 MByte	1.1 GHz	2.4 GHz	12	no	PC Client
Pentium®	N4200E	6 W	4	4	2 MByte	1.1 GHz	2.5 GHz	18	no	PC Client
Intel Atom®	x5-E3930	6.5 W	2	2	2 MByte	1.3 GHz	1.8 GHz	12	yes	Embedded
Intel Atom®	x5-E3940	9.5 W	4	4	2 MByte	1.6 GHz	1.8 GHz	12	yes	Embedded
Intel Atom®	x7-E3950	12 W	4	4	2 MByte	1.6 GHz	2.0 GHz	18	yes	Embedded

* The COMe-cAL6 doesn't support ECC memory

BLOCK DIAGRAM

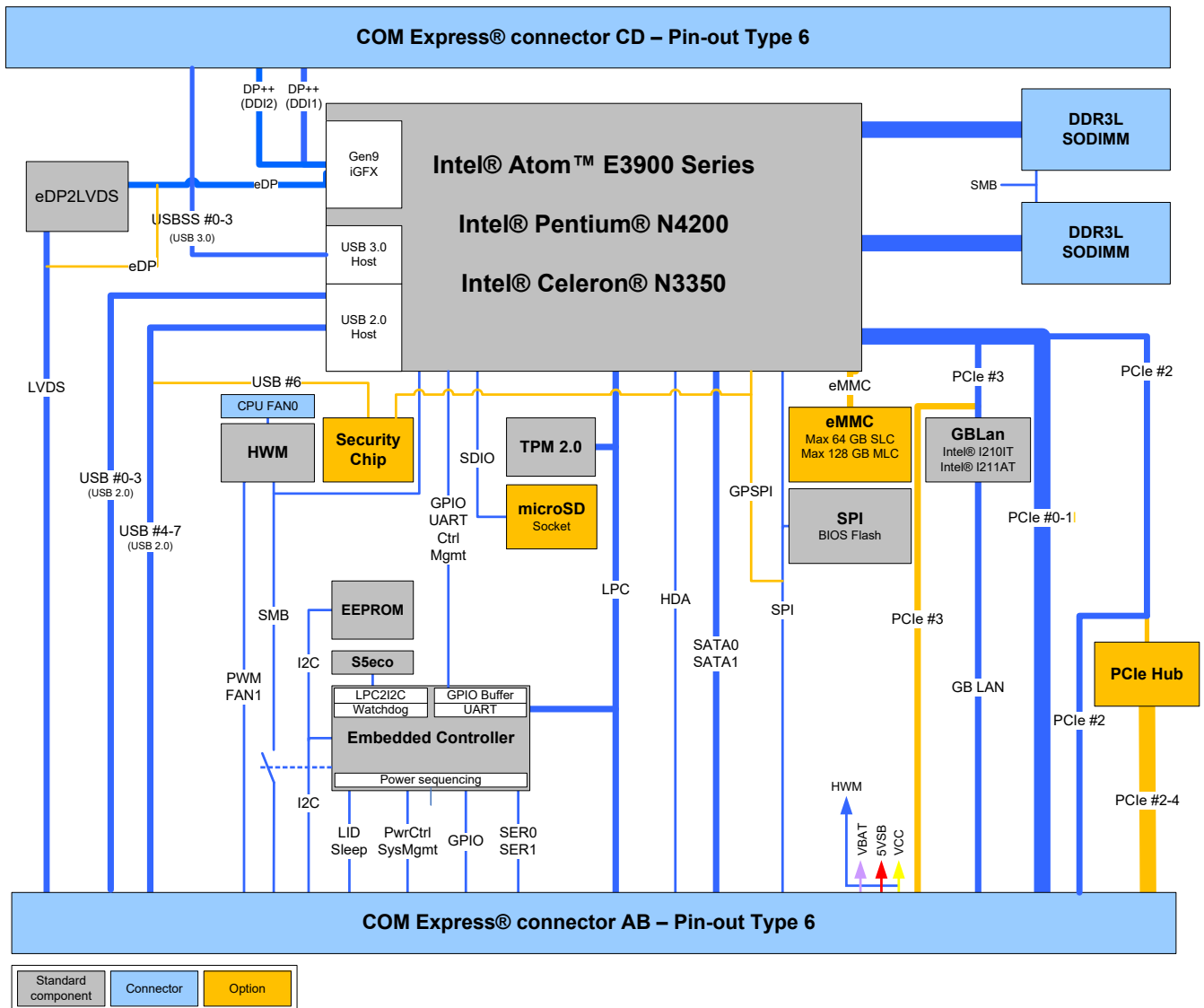

▶ VARIANTS

PART NO.	CPU	SO-DIMM	ETHERNET	PCI-E LANES	FLASH - eMMC	VARIOUS	OP. TEMPERATURE
36023-0000-11-2	N3350E	DDR3L-1866 non ECC	I211AT	3	no	LPC, LVDS, no SecurityChip	0 °C - 60 °C
36023-0000-11-4	N4200E	DDR3L-1866 non ECC	I211AT	3	no	LPC, LVDS, no SecurityChip	0 °C - 60 °C
36024-0000-13-5	E3930	DDR3L-1866 non ECC	I210IT	3	no	LPC, LVDS, no SecurityChip	-40 °C - 85 °C
36024-0000-16-5	E3940	DDR3L-1866 non ECC	I210IT	3	no	LPC, LVDS, no SecurityChip	-40 °C - 85 °C
36024-0000-16-7	E3950	DDR3L-1866 non ECC	I210IT	3	no	LPC, LVDS, no SecurityChip	-40 °C - 85 °C
36024-0032-16-7	E3950	DDR3L-1866 non ECC	I210IT	5	32 GByte pSLC	LPC, LVDS, no SecurityChip	-40 °C - 85 °C

Please contact your sales representative for other versions.

▶ CARRIER

ARTICLE	PART NO.	DESCRIPTION
COMe EVAL CARRIER2 T6	38116-0000-00-5	COM Express® Eval Carrier Type 6
COMe REF.CARRIER-I T6 TMI	38115-0000-00-0	COM Express® Reference Carrier Type 6 for industrial temperature - professional

▶ COOLING

ARTICLE	PART NO.	DESCRIPTION
HSP COMe-cAL6 (E2) THREAD	36024-0000-99-0	Heatspreader for COMe-cAL6 commercial and E2, threaded mounting holes
HSP COMe-cAL6 (E2) THROUGH	36024-0000-99-1	Heatspreader for COMe-cAL6 commercial and E2, through holes
COMe ACTIVE UNI COOLER (W/O HSP)	36099-0000-99-0	COM Express® Universal Active Cooler for Heatspreader Mounting (87x78x14.3 mm) (for CPU's <20 W)
COMe PASSIVE UNI COOLER (W/O HSP)	36099-0000-99-1	COM Express® Universal Passive Cooler for Heatspreader Mounting (87x78x14.3 mm)
COMe PASSIVE UNI COOLER2 SLIM (W/O HSP)	36099-0000-99-3	COM Express® Universal Passive Cooler low profile for Heatspreader Mounting (95x95x10 mm) 90° fin direction mounting option

▶ MEMORY

PART NO.	MIN. SPEC.	SIZE	ECC	OP. TEMPERATURE
97015-4096-19-0	DDR3L-1866	4 GByte	No ECC	0 °C to +60 °C
97015-8192-19-0	DDR3L-1866	8 GByte	No ECC	0 °C to +60 °C
97015-4096-19-2	DDR3L-1866	4 GByte	No ECC	-40 °C to +85 °C
97015-8192-19-2	DDR3L-1866	8 GByte	No ECC	-40 °C to +85 °C

▶ GLOBAL HEADQUARTERS

Kontron Europe GmbH

Gutenbergstraße 2
85737 Ismaning, Germany
Tel.: +49 821 4086-0
Fax: +49 821 4086-111
info@kontron.com

www.kontron.com